

Each problem is worth 1 point.

Perform the following operations :

Express the following numbers in scientific notation as numbers between 1 and 10 times the appropriate power of 10.

1.a) $437,276 =$ _____

b) $0.0000187 =$ _____

2.a) $267.9 \times 10^8 =$ _____

b) $0.0436 \times 10^{-4} =$ _____

Perform the following calculations :

3.a) $3.07 \times 10^8 - (2.23 \times 10^2)^2 \times 4.56 \times 10^3 =$ _____

b) $1.60 \times 10^{-19} \text{As} \times \frac{6.02 \times 10^{23}}{1 \text{g}} =$ _____

Perform the following unit conversions :

4. $1.57 \text{ mm} =$ _____ $\mu\text{m} =$ _____ m

5. $18.85 \text{ KHz} =$ _____ $\text{MHz} =$ _____ Hz

6. $16.89 \mu\text{V} =$ _____ $\text{mV} =$ _____ V

7. $10.9 \text{ M}\Omega =$ _____ $\text{K}\Omega =$ _____ Ω

8. $3.78 \text{ in} =$ _____ $\text{cm} =$ _____ mm (3 significant digits)

9. The dimensions of a rectangular integrated circuit are $6.5 \text{ mm} \times 1.0 \text{ cm}$. Calculate the area, A , to 3 significant digits.

$A =$ _____ $\text{cm}^2 =$ _____ $\text{mm}^2 =$ _____ $\text{m}^2 =$ _____ in^2

10. The capacitance, C , of a parallel plate capacitor is given by the following formula :

$$C = \frac{8.85 \text{ pF}}{\text{m}} \left(\frac{\epsilon A}{d} \right) \quad , \text{ where } \quad \epsilon \text{ is the dielectric constant of the insulating medium}$$

A is the effective plate area

d is the effective plate separation .

If an electrolytic capacitor has $\epsilon = 5.20$, $A = 12.3 \text{ cm}^2$ and $d = 4.3 \mu\text{m}$, calculate C (to 3 significant digits).

$C =$ _____ $\text{pF} =$ _____ $\text{nF} =$ _____ $\mu\text{F} =$ _____ mF

11. If line L_1 is parallel to line L_2 and $\angle CAB = 76^\circ 59'$ and $\angle CBA = 46^\circ 29'$ and $\angle CEG = 61^\circ 29'$ find the requested missing angles.

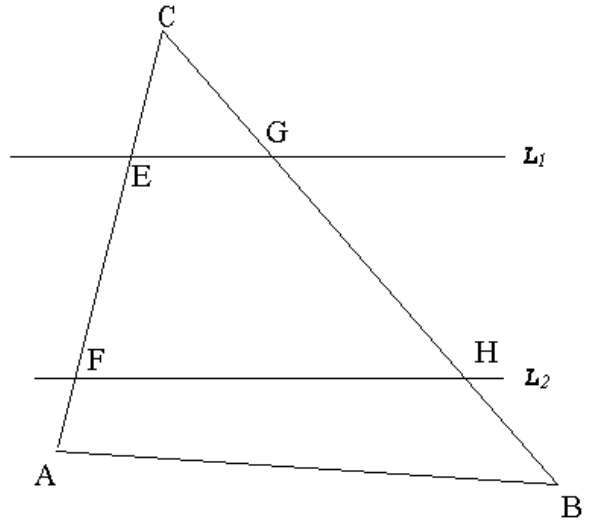

$\angle ACB =$ _____ $\angle CFH =$ _____ $\angle CGE =$ _____

12. Find the measure of the missing angles.

$\angle 2 =$ _____ $\angle 3 =$ _____

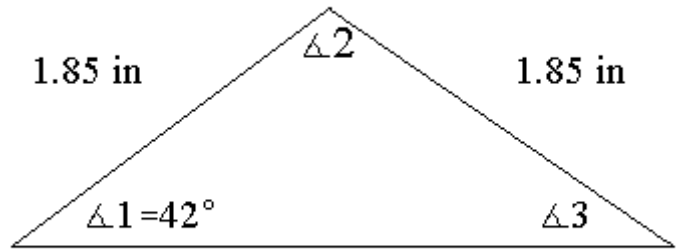

For each figure below calculate both the area, A , and the distance around (perimeter or circumference), P or C .

13. $P =$ _____ $A =$ _____

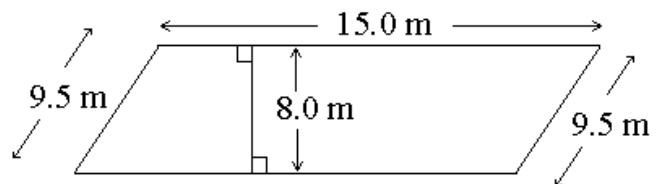

14. $P =$ _____ $A =$ _____

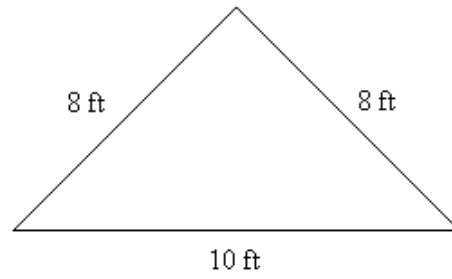

15. $P =$ _____ $A =$ _____



16. $C =$ _____ $A =$ _____

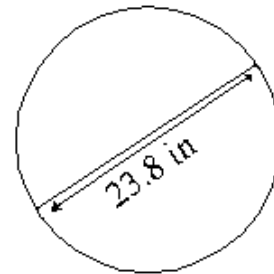

For each figure below calculate the requested missing information.

17. $\angle 1 =$ _____ $a =$ _____

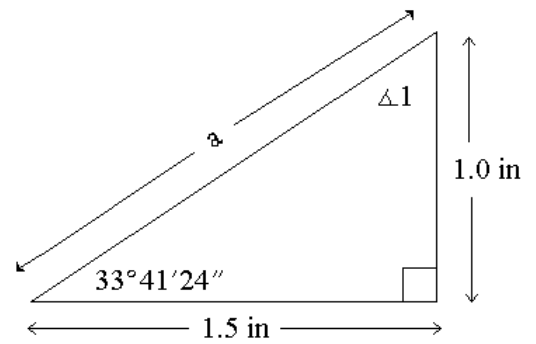

18. $P =$ _____ $A =$ _____ $\angle 1 =$ _____ $a =$ _____

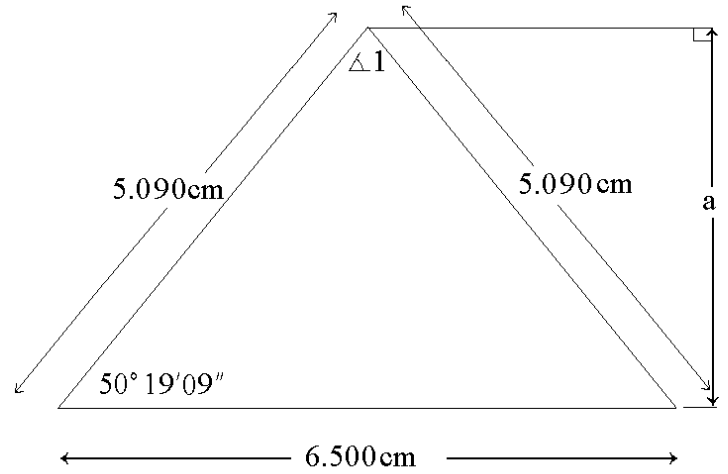

19. How many square feet of flooring does the following room have? $A =$ _____

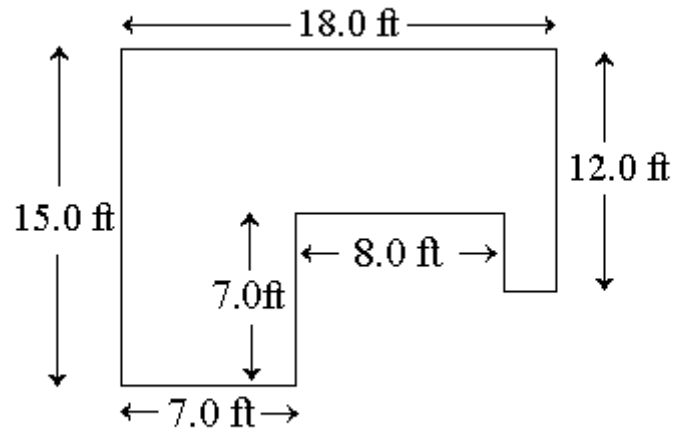

20. A 2.25 cm diameter hole is drilled in a 4.5 cm diameter circle. What area is left after the hole has been drilled?

21. The cross section of a shed is shown below. Determine the height h above the ground and the total area of the building's cross section.

$h =$ _____ $A =$ _____

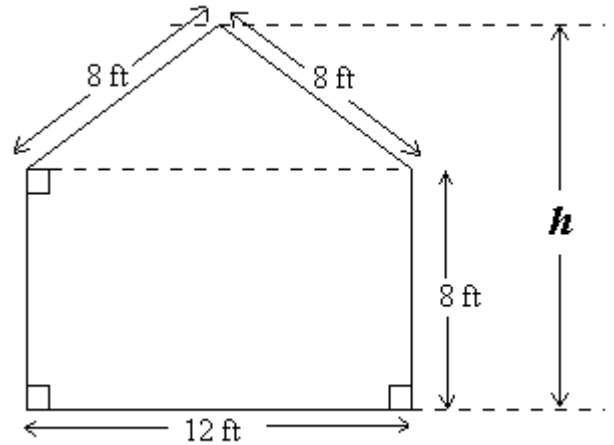

Find the lateral surface area, S , the total surface area, A , and the the volume, V , of the following solids.

22. $S =$ _____ $A =$ _____ $V =$ _____

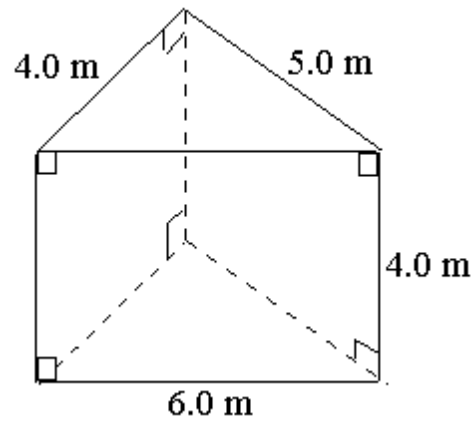

23. $S =$ _____ $A =$ _____ $V =$ _____

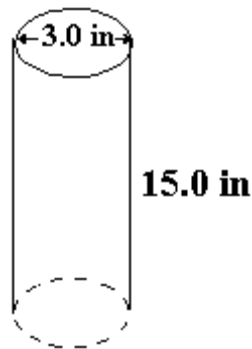

24. $S =$ _____

$A =$ _____

$V =$ _____

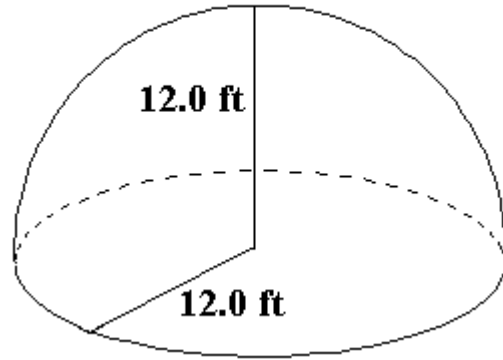

25. A cylindrical holding tank has an inner diameter of 40.0 ft and walls that are 18 in thick. The tank is designed to hold 350,000 gallons. What is the height, h , of the tank in feet?

$h =$ _____

Problems 1 through 8 are each worth 2 points, problems 9, 10 and 11 are each worth 3 points.

1. Convert the following angles from decimal degree measure to degree minute second measure : (to the nearest second)

Deg. Min. Sec. ($^{\circ} ' ''$)

- a) 47.45° = _____
- b) 124.377° = _____
- c) 29.125° = _____
- d) 0.18907° = _____

2. Convert the following angles from degree minute second measure to decimal degree measure : (4 decimal places)

Decimal Degrees

- a) $12^{\circ}39'42''$ = _____
- b) $63^{\circ}06'59''$ = _____
- c) $1^{\circ}13'02''$ = _____
- d) $12'10''$ = _____

For each angle give the values of the six trig functions to 4 decimal places.

- 3.a) 30.53°
- cosine = _____ sine = _____ tangent = _____
- cotangent = _____ secant = _____ cosecant = _____
- b) $61^{\circ}46'23''$
- cosine = _____ sine = _____ tangent = _____
- cotangent = _____ secant = _____ cosecant = _____

4. Given that $\sin \theta = 0.67$ and θ is between 0° and 90° , determine the following:

Decimal Degrees (4 places)

Deg. Min. Sec. ($^{\circ} ' ''$)

- θ = _____
- $\cos \theta$ = _____ $\sin \theta$ = _____ $\tan \theta$ = _____
- $\cot \theta$ = _____ $\sec \theta$ = _____ $\csc \theta$ = _____

5. Given that $\tan \theta = 1.50$, and θ is between 0° and 90° , determine the following:

Decimal Degrees (4 places)

Deg. Min. Sec. ($^{\circ} ' ''$)

- θ = _____
- $\cos \theta$ = _____ $\sin \theta$ = _____ $\tan \theta$ = _____
- $\cot \theta$ = _____ $\sec \theta$ = _____ $\csc \theta$ = _____

Solve for the missing sides (3 significant digits) and angles (decimal degrees, 2 places) in the following right triangles. The notation is that the angle whose measure is specified by the capital letter is opposite the side whose length is specified by the lower case letter.

6. $a = 3.00 \text{ ft}$ $b = 4.00 \text{ ft}$ $c = \underline{\hspace{2cm}}$
 $A = \underline{\hspace{2cm}}$ $B = \underline{\hspace{2cm}}$ $C = 90^\circ$

7. $a = \underline{\hspace{2cm}}$ $b = \underline{\hspace{2cm}}$ $c = 10.0 \text{ cm}$
 $A = 30^\circ$ $B = \underline{\hspace{2cm}}$ $C = 90^\circ$

8. $a = 1.894 \text{ m}$ $b = \underline{\hspace{2cm}}$ $c = \underline{\hspace{2cm}}$
 $A = 10.56^\circ$ $B = \underline{\hspace{2cm}}$ $C = 90^\circ$

9. After leaving a gas station in the western United States, a car travels N33°E (i.e., 33° east of north) for 23 minutes at a speed of 60 mph . Give all answers to three significant digits.

At the end of these 23 minutes how many miles from the gas station is the car?

At the end of these 23 minutes how many miles east of the gas station is the car?

At the end of these 23 minutes how many miles north of the gas station is the car?

10. A manufacturing plant is designed to be in the shape of a regular pentagon with 100 ft on each side. A security fence is to surround the plant and form a circle such that each corner of the building is to be 30 ft from the closest point on the fence. Determine the amount of fencing required.

11. A surveyor sights a mountain peak and measures an angle of elevation (to the nearest tenth of a degree) of 69.8°. She then advances 350 m closer to the peak and measures a new angle of elevation of 74.4°. Determine the height of the mountain peak above the level of the surveyor.

Problems 1 through 16 are each worth 1 point. Problems 17, 18, and 19 are each worth 2 points. Problem 20 is worth 3 points.

1. Convert the following angles from degree measure to both radian measure and the number of revolutions: (4 decimal places)

- | | | Radians | | Revolutions |
|----|------|---------|---|-------------|
| a) | 47° | = _____ | = | _____ |
| b) | 135° | = _____ | = | _____ |
| c) | 270° | = _____ | = | _____ |

2. Convert the following angles from radian measure to both degree measure and the number of revolutions: (4 decimal places)

- | | | Decimal Degrees | | Deg. Min. Sec. | | Revolutions |
|----|------------------|-----------------|---|----------------|---|-------------|
| a) | $\frac{\pi}{12}$ | = _____ | = | _____ | = | _____ |
| b) | $-\frac{\pi}{4}$ | = _____ | = | _____ | = | _____ |
| c) | 0.125 | = _____ | = | _____ | = | _____ |

3. For each angle in the table below give the quadrant of the angle and the sign of the value of the stated trig function. Angles not accompanied by a degree sign are in radians.

Angle (\angle)	Quadrant of \angle	Sign of Sine	Sign of Cosine	Sign of Tangent
200°				
300°				
86°				
- 135°				
- 600°				
$\frac{7\pi}{4}$				
$\frac{3\pi}{4}$				
1.95				
- 6.8				

4. Given that $\tan \theta = 0.75$ and $\cos \theta$ is negative, determine the following:

- | | Radians (4 places) | Decimal Degrees (4 places) | Deg. Min. Sec. ($^{\circ} ' ''$) |
|---------------|--------------------|----------------------------|------------------------------------|
| θ | = _____ | = _____ | = _____ |
| $\cos \theta$ | = _____ | $\sin \theta$ = _____ | $\tan \theta$ = _____ |
| $\cot \theta$ | = _____ | $\sec \theta$ = _____ | $\csc \theta$ = _____ |

5. Given that $\cos \theta = \frac{3}{4}$ and $\tan \theta$ is negative, determine the following:

	Radians (4 places)	Decimal Degrees (4 places)	Deg. Min. Sec. ($^{\circ} ' ''$)
θ	= _____	= _____	= _____
$\cos \theta$	= _____	$\sin \theta$	= _____
$\cot \theta$	= _____	$\sec \theta$	= _____
		$\tan \theta$	= _____
		$\csc \theta$	= _____

6. To three significant digits find the arclength subtended by an angle of 16.5° and a radius of 13.9 in .

7. The sun is approximately 93,000,000 miles from the earth. If the diameter of a circular sunspot as measured on earth takes up $4''$ of arc, what is the sunspot's diameter in miles (2 significant digits)?

8. Find the angle, θ , in both radians and decimal degrees subtended by an arc of 15.0 cm in a circle of diameter 50.0 cm .

	rads (4 sig digits)	degrees (4 sig digits)
θ	= _____	= _____

9. Find the area of the sector of a circle of diameter 60.0 ft subtended by an angle of 12.0° .

10. A bicyclist pedals at such a rate that both wheels rotate at 184 rpm. The outside wheel diameter is 26.0 in . Assuming that the tires never slip against the ground, what is the bicyclist's speed?

	ft/min (3 sig digits)	mph (3 sig digits)
speed	= _____	= _____

11. A 6.0 mm diameter drill bit rotates at 900 rpm, to two significant digits, what is the linear velocity of a point on the circumference of the bit?

	mm/min (3 sig digits)	ft/sec (3 sig digits)
velocity	= _____	= _____

Solve for the missing sides (3 significant digits) and angles (decimal degrees, 3 places) in the following triangles. Include **all possible** solutions. The notation is that the angle whose measure is specified by the capital letter is opposite the side whose length is specified by the lower case letter.

12. $a = 12.5 \text{ m}$ $b = 11.6 \text{ m}$ $c = \underline{\hspace{2cm}}$

$A = \underline{\hspace{2cm}}$ $B = \underline{\hspace{2cm}}$ $C = 35^\circ$

13. $a = 8.50 \text{ in}$ $b = 10.0 \text{ in}$ $c = 6.00 \text{ in}$

$A = \underline{\hspace{2cm}}$ $B = \underline{\hspace{2cm}}$ $C = \underline{\hspace{2cm}}$

14. $a = \underline{\hspace{2cm}}$ $b = \underline{\hspace{2cm}}$ $c = 10.0 \text{ cm}$

$A = 40.00^\circ$ $B = 25.00^\circ$ $C = \underline{\hspace{2cm}}$

15. $a = 10.0 \text{ in}$ $b = 13.0 \text{ in}$ $c = \underline{\hspace{2cm}}$

$A = 40.00^\circ$ $B = \underline{\hspace{2cm}}$ $C = \underline{\hspace{2cm}}$

16. $a = 13.0 \text{ in}$ $b = 10.0 \text{ in}$ $c = \underline{\hspace{2cm}}$

$A = 40.00^\circ$ $B = \underline{\hspace{2cm}}$ $C = \underline{\hspace{2cm}}$

17. A state police helicopter at an altitude of 800 ft is following two cars down a straight stretch of highway. The angle of depression (made with the horizontal) from the helicopter to the lead car is 47.6° , while the angle of depression to the rear car is 52.5° . To the nearest foot, how far apart are the two cars?

18. Two airplanes leave the same airport at the same time. The planes are traveling at speeds of 340 miles per hour and 380 miles per hour respectively. After two and one-half hours the airplanes are 650 miles apart. What is the angle (to two decimal places) between their courses of flight?

19. At a particular time, the angle between the line joining Venus to the Earth and the line joining Earth to the Sun is 29° . The orbit of Venus around the Sun is approximately circular with a radius of 67 million miles. The Earth's orbit about the sun is also nearly a circle, having a radius of 93 million miles.

a) Estimate to the nearest million miles the possible values for the distance between the Earth and Venus at this time.

b) When Venus is 100 million miles from Earth, what is the angle between the line joining the Earth to the Sun and the line joining the Earth to Venus?

20. Generate a Winplot graph through the following procedure. **Attach** a printout of the graph with your quiz.

a) Using a 2-D window use the **View** menu to set left = -5.66473988 , right = 5.66473988 , down = -5 , up = 5 .

b) Using the **Anim** (Animate) menu, select R and in the "Current R-Value" dialogue box set the lower value (Set L) of R to 0 and the upper value of R (Set R) to 5.

c) Using the **Anim** menu, select A and in the "Current A-Value" dialogue box set the lower value (Set L) of A to 0 and the upper value of A (Set R) to 4π (Pi).

d) Using the **Anim** menu, select B and in the "Current B-Value" dialogue box set the lower value (Set L) of B to 0 and the upper value of B (Set R) to 6π (Pi).

e) In the **Equa** menu choose Polar and enter R for the right side of $f(t) =$ (i.e., $f(t)=R$). Use the defaults (0 and 2π) for low t and high t. This equation will generate a circle of radius R centered at the origin. Moving the scroll bar on the "Current R-Value" dialogue box will dynamically vary the radius.

f) In the **Equa** menu choose Point $\rightarrow (x, y)$ and enter $R\cos(A)$ for the right side of $x =$ (i.e., $x = R\cos(A)$) and $R\sin(A)$ for the right side of $y =$ (i.e., $y = R\sin(A)$). Choose a color for this point different from the color of the circle generated in step e). This equation will generate a point which will change position by moving the scroll bar on the "Current A-Value" dialogue box.

g) In the **Equa** menu choose Point $\rightarrow (x, y)$ and enter $R\cos(-B)$ for the right side of $x =$ (i.e., $x = R\cos(-B)$) and $R\sin(-B)$ for the right side of $y =$ (i.e., $y = R\sin(-B)$). Choose a color for this point different from the previous colors of steps e) and f). This equation will generate a point which will change position by moving the scroll bar on the "Current B-Value" dialogue box.

Answer the following questions:

A) As you move the scroll bar on the "Current R-Value" dialogue box explain what happens to the two points of steps f) and g).

B) As you move the scroll bar on the "Current A-Value" dialogue box explain what happens to the the point of step f).

C) How many full turns does the point of step f) make as you vary the "Current A-Value" from left to right?

D) As you move the scroll bar on the "Current B-Value" dialogue box explain what happens to the the point of step g).

E) How many full turns does the point of step g) make as you vary the "Current B-Value" from left to right?

Name _____

Each problem is worth 2.5 points.

1. A plane takes off with a heading of $N71^\circ E$ and a ground speed of 211 mph. At 5000 ft, after encountering strong winds, the plane's 'true course' becomes $N65^\circ E$ with a ground speed of 223 mph.

a) What is the wind's direction?

b) What is the wind speed?

2. A 100 lb force down and a 50 lb force which makes an angle of $+10^\circ$ with the right horizontal is balanced by a third force.

a) What is the magnitude of this third force?

b) What is the orientation of this third force?

3. It takes a force of 80 lbs to pull a 200 lb object up an inclined plane. What angle does the inclined plane make with the ground? (Ignore any effects due to friction.)

4. A 600 lb weight is suspended from a ceiling by two stiff support rods. Each rod is anchored both into the ceiling and into the weight. The angle between the two support rods at the weight is 90° . If the right-most rod makes an acute angle of 45° with the ceiling at its point of support, with what total force does it pull on the 600 lb weight?

Graph the following trigonometric functions for $-2\pi \leq x \leq 2\pi$ and supply the requested information. If you wish you may hand in computer generated plot.

5. $y = 2\sin(x)$ Period = _____ Amplitude = _____

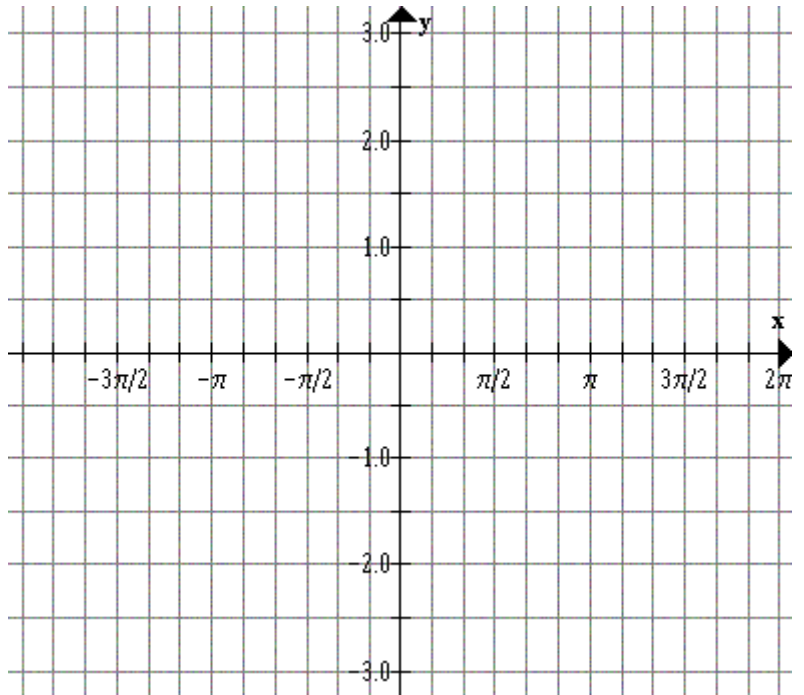

6. $y = 2\sin(2x)$ Period = _____ Amplitude = _____

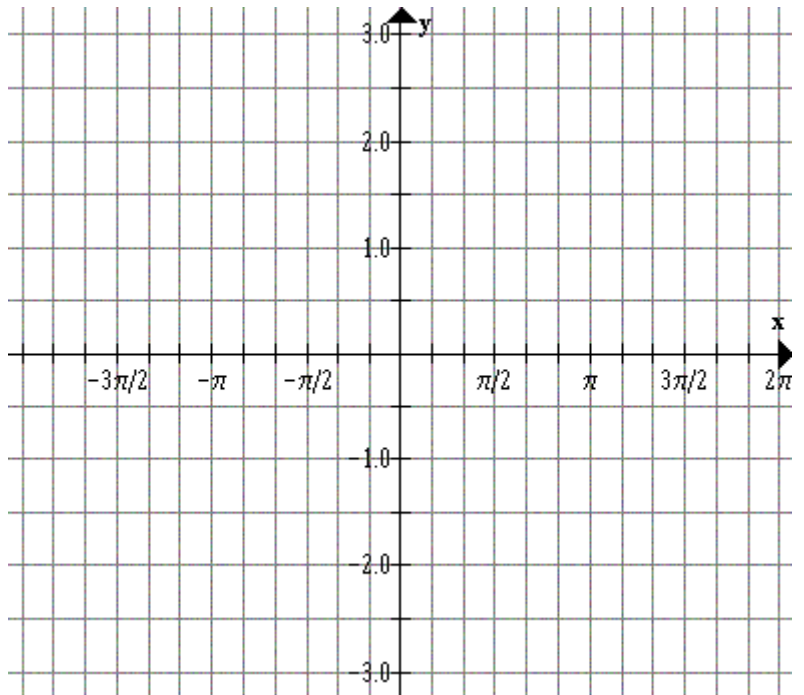

7. $y = 3\sin\left(\frac{x}{2}\right)$

Period = _____ Amplitude = _____

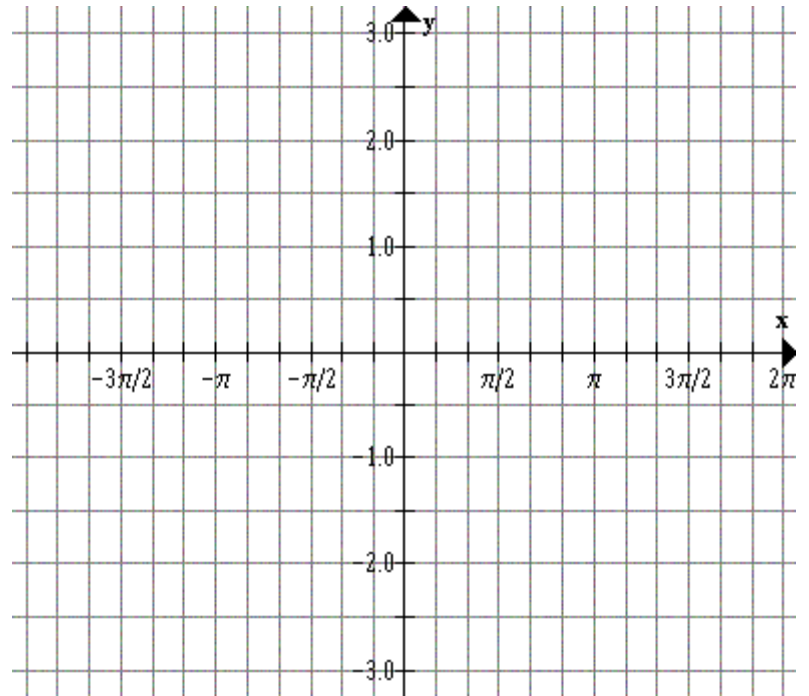

8. $y = -2\cos(3x)$

Period = _____ Amplitude = _____

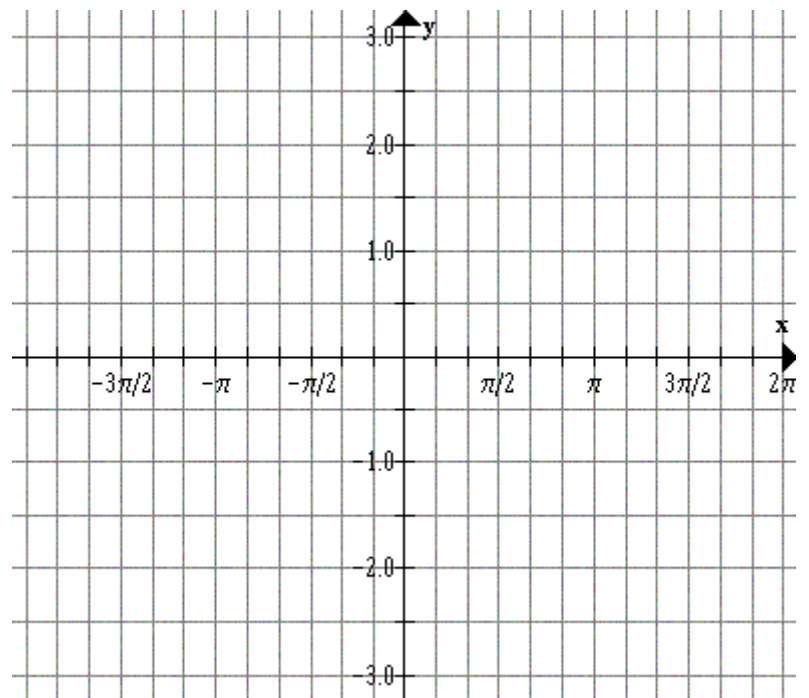

9. $y = \tan(x)$

Period = _____

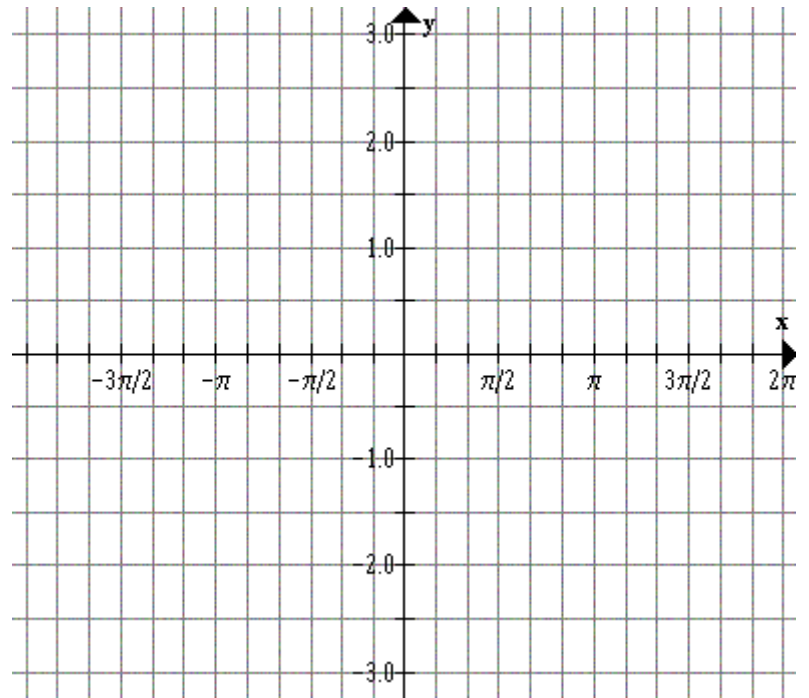

10. $y = \sec(x)$

Period = _____

